

**CONTENTS**

- Trend
- Screws
- Closing plug

**TOOLS REQUIRED**

- Saw
- Tape measure
- Pencil/marker
- Drill and drill bit
- Router
- Chisel
- Allen key

**CUT BACK SIZE ALLOWANCE**

Trend can be cut back by up to 150mm  
 330mm can be cut back by 50mm  
 430mm can be cut back by 135mm

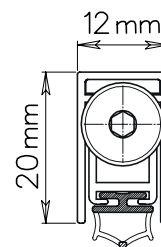

1

If the door is already installed, remove from its hinges and use a router to create a groove along the entire width of the bottom of the door, following the dimensions of the Trend - 12 x 20mm, with an allowance of +0.5mm.

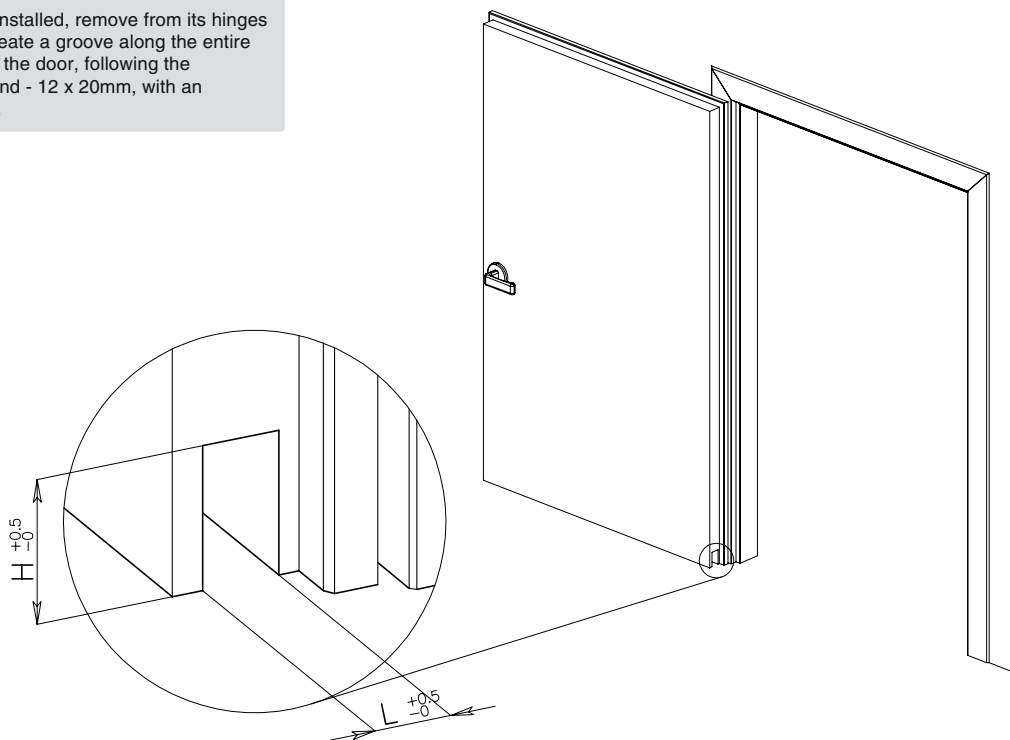

2

Measure the width of the door minus 5.5mm and cut back the seal using a power/hack saw. Remove any excess debris.

Do not cut back the seal more than what is permitted (refer to the cut back allowance).

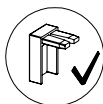
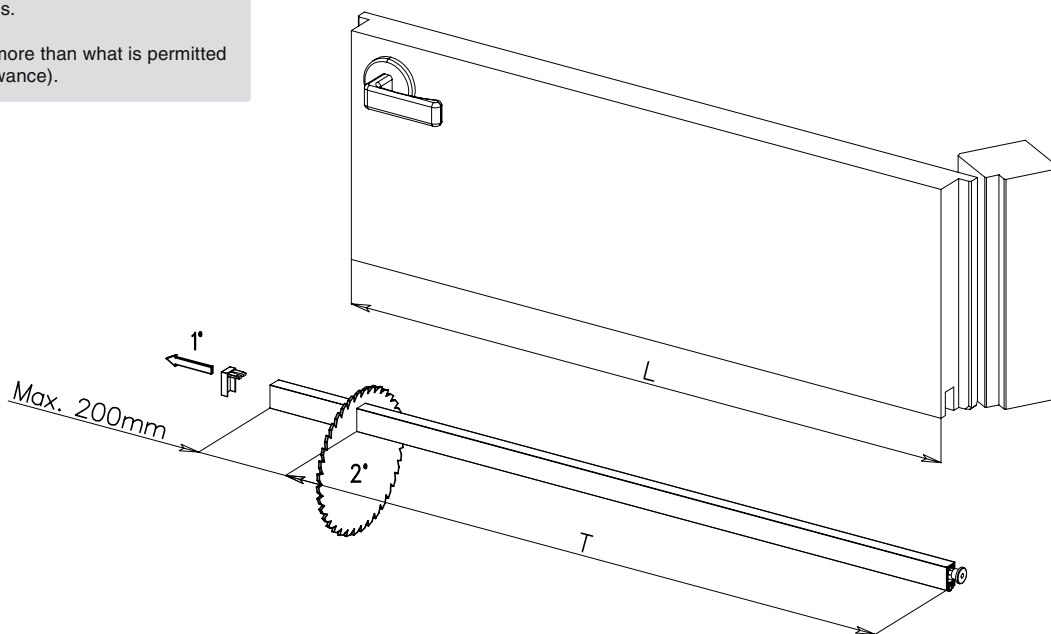

T=L-5.5 mm



T=L

3

Insert the seal into the groove, ensuring the actuator button is on the hinge side, and partially slide out the silicone gasket to reveal the fixing holes.

Fix the drop seal to the door leaf using the screws provided and slide the gasket back into place.

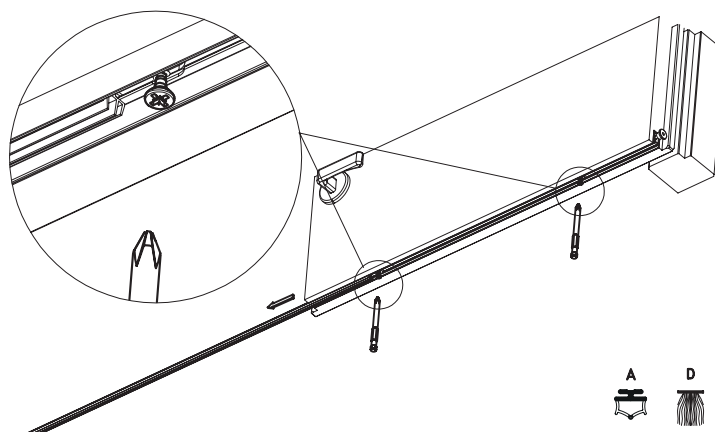

4

Hang the door back onto its hinges and securely fasten the closing plug into place on the lock side of the seal.

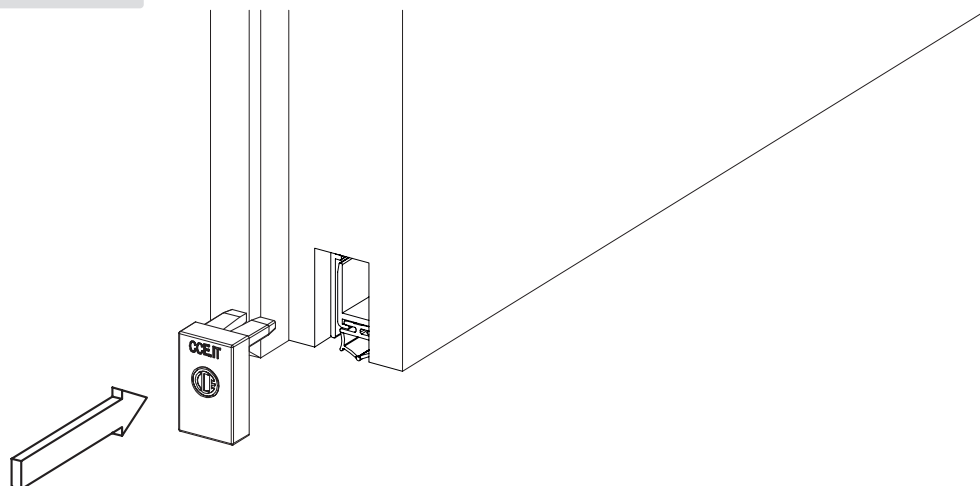

5

**PLUNGER ADJUSTMENT**

Observe the seal and adjust accordingly by using a 3mm Allen key to rotate the actuator button.

Rotate clockwise to reduce seal movement or anticlockwise to increase seal movement, ensuring the seal makes contact with the floor.

