

SUPERIOR

CE1435SP6

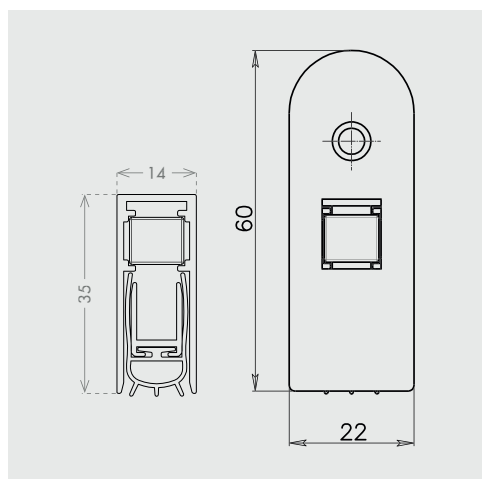

ITEM SIZE (mm)

14 x 35

GROOVE SIZE (mm)

14,1 x 35

AVAILABLE LENGTHS (mm)

330 - 430 - 530 - 630 - 730 - 830 - 930 - 1030 - 1130 -
1230 - 1330 - 1430 - 1530

MATERIALS

- EXTERNAL PROFILE** 6060 T6 aluminium alloy
INTERNAL PROFILE 6060 T6 aluminium alloy
AVAILABLE FINISHING Mill
MECHANISMS Nylon PA6 30% Fiberglass reinforced
SEAL Q. Soft mono-extruded self-extinguishing thermoplastic.
CLOSING END-CAP Inox steel brackets for fixing and side closing.
ACTIVATION PLUNGER 8. Extractable squared nylon plunger with return spring. Manual adjustment. Nylon PA6 30% Fiberglass reinforced. Color: black.

TECHNICAL CHARACTERISTICS

- MAXIMUM DROP (mm)** 17
WORKING TEMPERATURES (C°) -20° / +80°
FIXING TYPE 1F. With stainless steel brackets (includes 3,5x20 countersunk nickel plated screws) or 3F. Removing the inner profile (screws not included).

CERTIFICATES

- WORKING CYCLES** > 200.000 (internal test)
ACOUSTIC INSULATION **48dB Rw** - Cert. n. PB-G03-04-en-01-PB03 - IFT Rosenheim
FIRE RESISTANCE **120 mins** - Cert. n. 20/22763-1240-1 - Applus Laboratories
UL-10C - File n. R39141 - Underwriters Laboratories
SMOKE TESTED Cert. nr. WYC501934/01/Rev1/A, Warrington Fire



APPROVED PRODUCT
CF 5995

SUPERIOR

CE1435SP6

ITEM LENGTH mm	ITEM WEIGHT Kgs	BOX WEIGHT Kgs	MAX TRIMMING mm	TRIMMING from -> to mm
330	0,172	5,000	50	330 -> 280
430	0,225	6,325	135	430 -> 295
530	0,278	7,650	150	530 -> 380
630	0,331	8,975	150	630 -> 480
730	0,384	10,300	150	730 -> 580
830	0,437	11,625	150	830 -> 680
930	0,490	12,950	150	930 -> 780
1030	0,543	14,275	150	1030 -> 880
1130	0,596	15,600	150	1130 -> 980
1230	0,649	16,925	150	1230 -> 1080
1330	0,702	18,250	150	1330 -> 1180
1430	0,755	/	150	1430 -> 1280
1530	0,808	/	150	1530 -> 1380

PACKAGING

MINIMUM PACKAGING Single piece (industrial)

BOX PACKAGING 25 pieces (except where noted)

ITEM AND PACKAGING CARE

Keep the items inside their original packaging. Keep the boxes in horizontal position, do not bend or overlap heavy weights.

Keep stored in a dry place, protected from water, solvents and direct sunlight.