

## Overhead Closer

### Introduction

The Briton 2003 is a fixed power size EN 3 overhead door closer. Well known for its robust and reliable performance year after year, with minimal adjustments and maintenance. This often imitated never bettered closer is easy to install saving time with its accufit template and instructions.

### Features & Functions

- Fixed power size EN 3
- Certified, UKCA and CE marked in Regular, Transom and Parallel applications
- Adjustable closing speed & latch action
- Stylish flatform arm in finish to match door closer cover
- Universal fittings for Regular or Transom mount fixing
- Self-adhesive Accufit template for quick, accurate installation
- Suitable for fire rated doors in Regular, Transom and Parallel applications
- Classic robust Briton cover with authentic badge conceals fixings and adjustment screws
- Optional hold-open armset (for non-fire doors only).



2003.SES



### Certification

UKCA Marked to EN 1154 (1121-CPR-UK-AD7576)

CE Marked to EN 1154 (2812-CPR-AD0013)

Certifire Approved (regular & transom applications only) (CF111)

Fire tested to EN 1634-1 for use on fire doors up to 2hr timber / 4hr steel [*\* May be fitted to fully insulated steel based doorsets or uninsulated steel based doorsets where the closer is fitted to the fire risk face only*].

Environmental Product Declaration in accordance with ISO 14025 & EN 15804

DoP available at [www.britondops.co.uk](http://www.britondops.co.uk)

## Overhead Closer Briton 2003

Product features	Product references
	<b>2003</b>
Closer type	Projecting/scissor arm
UKCA & CE marked	■
Fixed closing power EN size	3
Door limits (width/weight)	950mm/60kg
Maximum angle of opening	180°
Adjustable closing speed & latch action	■
Tri-pack armset	■
Mechanical hold-open facility (non fire doors only)	□
Cover variants	Classic C cover
Finishes available	SES
<b>CE Classification</b>	<b>4 8 3 1 1 3</b>

■ Standard    □ Available as an option/variant

Accessories & Parts for Briton 2003	
2000.AP	Arm pack
2000.APH	Hold-open arm pack
2000.CP	Cover pack
2000.FP	Fixing pack
2003V.BRK66	Fig.66 bracket pack

Closer with Classic cover

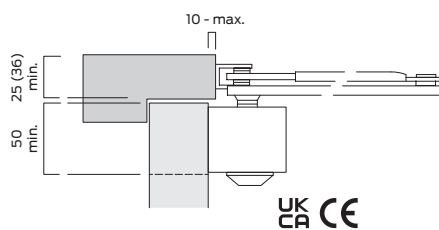
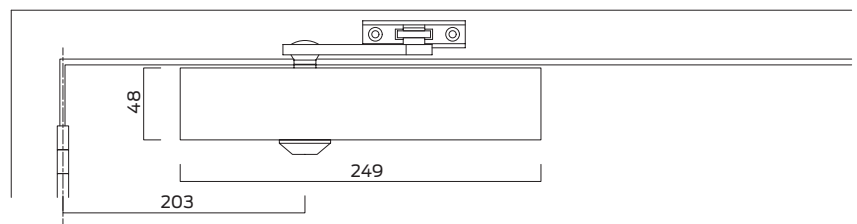
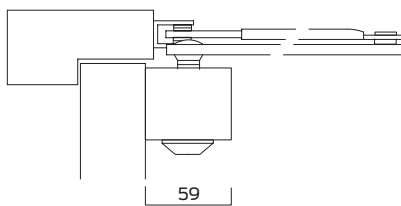

Fig.1  
Door mount pull side

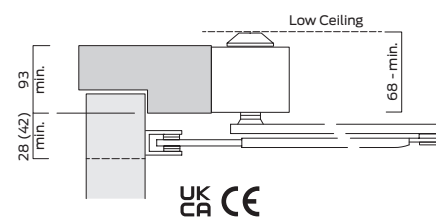

Fig.61  
Transom mount push side

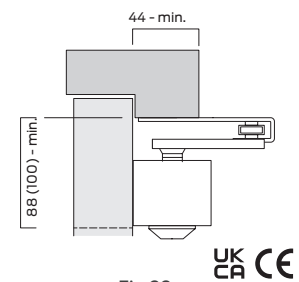
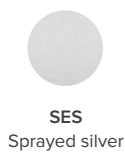

Fig.66  
Parallel arm push side mount

All dimensions are in mm  
(Dimensions in brackets are when used with hold-open armset option)

### Finishes

Supplied with matching armset and brackets.



## Overhead Closers

### Installation dimensions

#### Regular Application [Fig.1]

Door mounted application

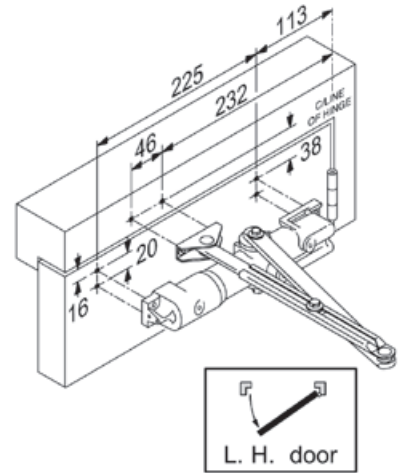
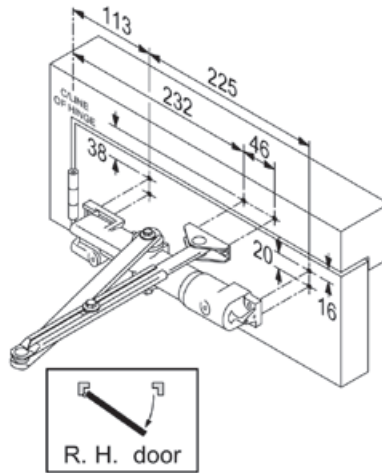

#### Transom Application [Fig.61]

Transom mounted push side

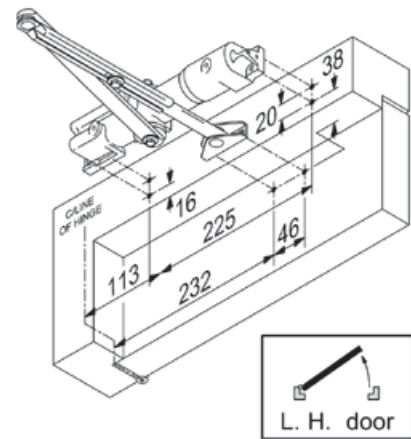
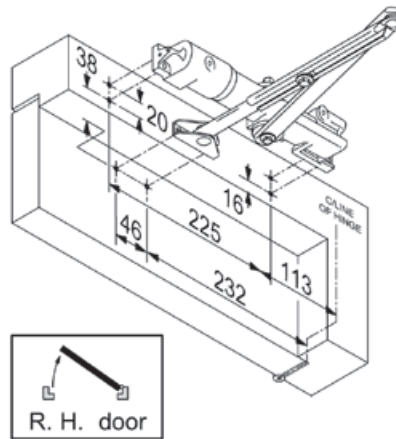

#### Parallel Arm Application [Fig.66]

Door mounted push side

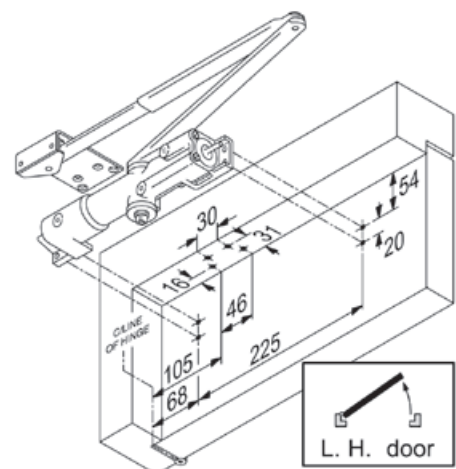
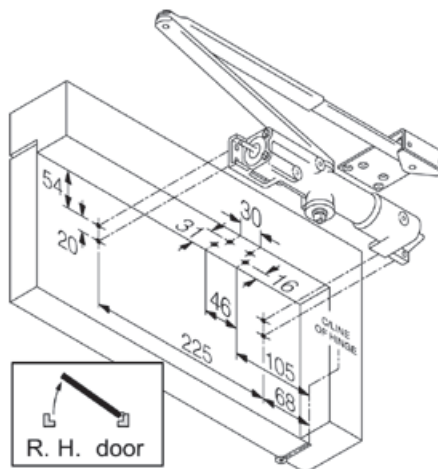

## General Maintenance

### Door controls

In research, Allegion has identified that 95% of all problems associated with overhead door closers can be attributed directly to errors in installation rather than problems with the door closer itself. If the door is not closing properly into the frame you should first disconnect the door closer (disconnect the arm(s)) and determine that there is not an underlying problem with the door, frame or any smoke / draft seals that might be fitted.

#### PLEASE NOTE:

The power of the door closer should not be used to overcome problems associated with the door or other items of hardware fitted to it. Under no circumstances should the closer body be dismantled.

### Types of maintenance

Much of the routine maintenance recommended consists of a combination of visual and mechanical checks, cleaning and lubrication. Look out for the icons opposite which provide a 'quick glance' reminder of the maintenance required.

#### Visual checks

Primarily making a visual check on the product and surrounding door/frame looking for wear, damage, and general condition.



#### Functional checks

Consists of checking that the product operates properly ensuring the door can fully close without any binding or undue force required. Check that any seals or weatherstripping do not inhibit correct operation of the door.



#### Check fixings

Fixings need to be checked regularly and tightened when necessary. Check that no projection of fixings prevents the door from swinging freely.



#### Lubricating

Some products will benefit from periodic lubrication using a light machine oil or as instructed.



#### Cleaning

Build up of grease, dust and harmful chemicals should be removed to prevent corrosion and maintain the product finish.



### Closer Maintenance

#### WEEKLY

Release the door from the fully open position and ensure that it closes fully into the frame. Ensure the latch (if fitted) engages fully into the strike plate. Repeat the process a few times from different angles of opening to ensure the door closes consistently each time.



Check and adjust the closing and latching speeds if necessary.

Check that the door or hardware does not come into contact with the door frame or the surrounding structure.



#### QUARTERLY

The fixings of the closer body and the bracket are subject to stress and should be checked carefully to make sure they are tight.



Periodically apply a little light machine oil to the moving joints of the arm and bracket.



Check any fire and smoke seals to ensure they do not foul the action of the door.



Check for any loss of fluid from the door closer body which would indicate a failing device.

Clean the closer body, arms and bracket if necessary following the guidance on "Care of Finishes" on page 16 of the 'Service & Maintenance Guide'.



#### FIRE DOOR APPLICATIONS

When installed as part of a fire precaution system the door closing mechanism, including the door selector if used on a double door arrangement, should be checked in accordance with standing periodic fire testing procedures.

Routinely check that all fixings of the closer body and bracket are tight.

Routine care of finishes as necessary.