

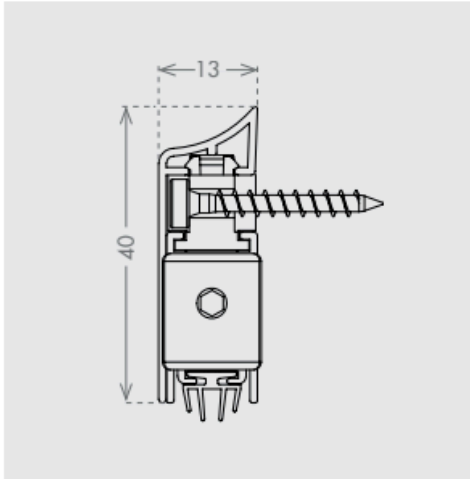

APPLIQUE

CE1340APP



ITEM SIZE (mm)

13 x 40

GROOVE SIZE (mm)

face-mounted

AVAILABLE LENGTHS (mm)

330 - 430 - 530 - 630 - 730 - 830 - 930 - 1030 - 1130 -
1230 - 1330 - 1430 - 1530

MATERIALS

EXTERNAL PROFILE 6060 T6 aluminium alloy

INTERNAL PROFILE 6060 T6 aluminium alloy

AVAILABLE FINISHING White RAL9010, Brown RAL8017, Silver anodized

MECHANISMS Nylon PA6 30% Fiberglass reinforced

SEAL A. Four lips co-extruded self-extinguishing thermoplastic seal. Color: black

CLOSING END-CAP + ACTIVATOR Included. Nylon PA6 30% Fiberglass reinforced. Color: grey.

ACTIVATION PLUNGER 9B. Nylon clad steel plunger, adjustable with a 3mm allen wrench. Color: grey.

TECHNICAL CHARACTERISTICS

MAXIMUM DROP (mm) 14

WORKING TEMPERATURES (°C) -35° / + 200°

FIXING TYPE 3F. with frontal screws, removing the cover (screws included).

CERTIFICATES

WORKING CYCLES > 200.000 (internal test)

ACOUSTIC INSULATION **29 dB Rw** - Cert. nr. 21-002394-PR01 – IFT Rosenheim

SMOKE TESTED Cert. nr. WYC 501934-02 Rev1, Warrington Fire



APPROVED PRODUCT
CF 5995

APPLIQUE

CE1340APP

ITEM LENGHT mm	ITEM WEIGHT Kgs	BOX WEIGHT Kgs	MAX TRIMMING mm	TRIMMING from -> to mm
330	0,172	5,00	20	330 -> 310
430	0,225	6,32	120	430 -> 310
530	0,278	7,65	150	530 -> 380
630	0,331	8,98	150	630 -> 480
730	0,384	10,30	150	730 -> 580
830	0,437	11,63	150	830 -> 680
930	0,490	12,95	150	930 -> 780
1030	0,543	14,28	150	1030 -> 880
1130	0,596	15,60	150	1130 -> 980
1230	0,649	16,93	150	1230 -> 1080
1330	0,702	18,25	150	1330 -> 1180
1430	0,755	/	150	1430 -> 1280
1530	0,808	/	150	1530 -> 1380
1630	/	/	/	1630 -> 1430
1730	/	/	/	1730 -> 1530
1830	/	/	/	1830 -> 1630

PACKAGING

MINIMUM PACKAGING single piece in nylon bag

BOX PACKAGING 25 pieces (except where noted)

ITEM AND PACKAGING CARE

Keep the items inside their original packaging. Keep the boxes in horizontal position, do not bend or overlap heavy weights.

Keep stored in a dry place, protected from water, solvents and direct sunlight.